

Urban: Sifon FONTA URBAN M125 400x400 iesire verticala Dn160 (33354/16-3)

33354/16-3

400 mm
HOSSZ

162 mm
MAGASSÁG

400 mm
SZÉLESSÉG



FELHASZNÁLÁS:

The ductile iron trap for sewage is a useful, pragmatic, and modern solution used for collecting rainwater and directing it toward underground sewage lines.

MINŐSÉGI FELTÉTELEK:

Compliant with SR EN 1253-1:2015.

ELŐNYÖK:

- Attractive design
- Watertightness
- Thermal and mechanical resistance
- Use in residential areas or private homes
- Long lifespan
- Anti-slip

TERMÉKGARANCIA:

50 years - with proper adherence to installation, storage, and operation instructions.

SZERELÉS

It can be installed in private premises, yards, industrial halls, paved paths, or in areas with light traffic resistance, underground or subterranean garages/parking lots, etc.

! For efficient installation, we recommend using the G12M29C sealant. It is used for sealing trenches, pipes, and drainage systems.



- Cure time: 24 hours for 2-3 mm thickness
- Operating temperature: -10° C to +40° C
- Storage conditions: Store in a ventilated space at low temperatures

BASE sealant, construction products, 310 ml tube (G12M29-C).

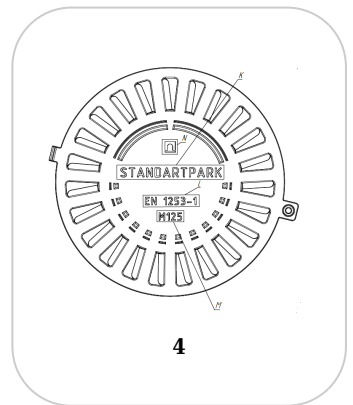
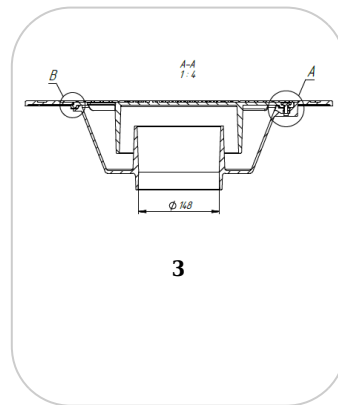
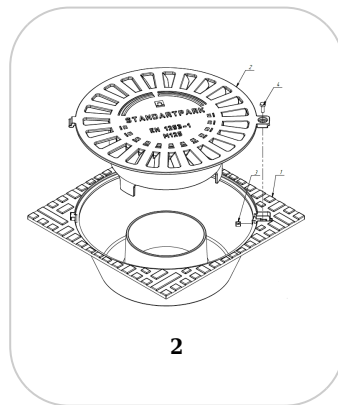
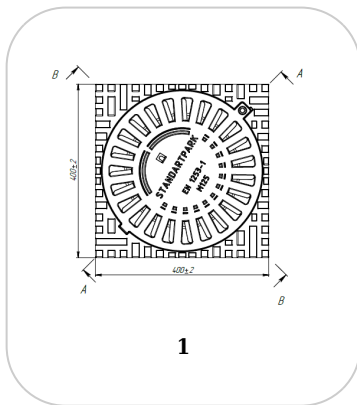

JELLEMZŐK

Termék neve	Sifon FONTA URBAN M125 400x400 iesire verticala Dn160 (33354/16-3)
Termékkód	33354/16-3
EAN kód	6427669001515
Termékkategória	Sifoane Fonta
Brand	Urban
Súly	8.30 kg
Készlet elérhetősége	Tárolható
Hossz, mm	400
Szélesség, mm	400
Magasság (M), mm	162
Belső átmérő / hézag (mm)	213
Külső átmérő (mm)	-
Terhességi osztály	M125
Termék anyaga	Öntöttvas
Rögzítőrendszer	
Termelő	