

Urban: GRATAR / GEIGER FONTA URBAN rotund D.800 PL.600 Hext.100 D400 (32158/10-55M)

32158/10-55M

800 mm
HOSSZ

100 mm
MAGASSÁG

800 mm
SZÉLESSÉG



FELHASZNÁLÁS:

D400 class covers and grates are intended for public traffic areas. They can be placed on shoulders, parking lots and parking spaces for all types of road vehicles.

MINŐSÉGI FELTÉTELEK:

- SR EN 124-2
- EU Regulation No. 305/2011
- Declaration of Performance

ELŐNYÖK:

- Use in industrial areas
- Easy to handle and install
- Long service life
- Balanced ratio between load class and product weight
- Anti-theft (secure and articulated fixing of the cover to the frame)

TERMÉKGARANCIA:

- 50 years - subject to compliance with assembly, storage and operation instructions.

SZERELÉS

Installation and commissioning shall only be carried out in areas compliant with the product's load class. Commissioning shall be carried out by specialized personnel.

! For efficient installation, we recommend using G12M29C sealant.

It is used for sealing gutters, pipes and drainage systems

- Curing time: 24h/2-3 mm
- Operating temperature: +5° C to +40° C
- Maximum storage temperature: 32° C



- BASE sealant, construction products, 310 ml tube (G12M29-C)

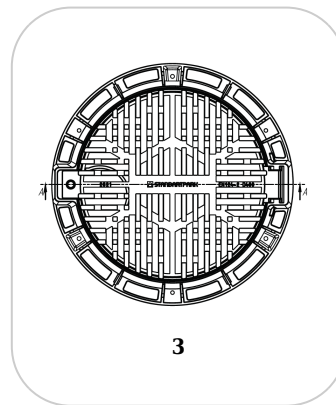
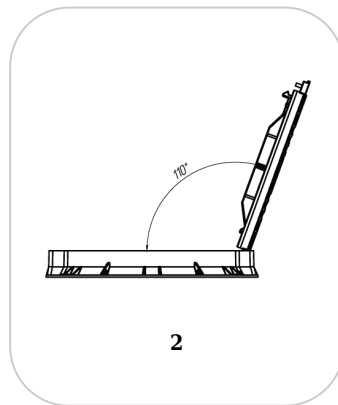

JELLEMZŐK

Termék neve	GRATAR / GEIGER FONTA URBAN rotund D.800 PL.600 Hext.100 D400 (32158/10-55M)
Termékkód	32158/10-55M
EAN kód	6427669001195
Termékkategória	Geiger canalizare din fonta (A15 - D400)
Brand	Urban
Súly	59.47 kg
Készlet elérhetősége	Egyedi gyártású
Magasság (M), mm	100
Belső átmérő / hézag (mm)	600
Külső átmérő (mm)	800
Terhességi osztály	D400
Termék anyaga	Öntöttvas
Rögzítőrendszer	
Garancia, hónap	24
Termelő	