

Drain: Gratar INOX STAINLESS tip fante pentru rigola LN150 M125 498x176x30 (990341)

990341

498 mm
HOSSZ

30 mm
MAGASSÁG

176 mm
SZÉLESSÉG



FELHASZNÁLÁS:

The grill is made of stainless steel and offers increased durability and corrosion resistance, making it ideal for use in indoor or outdoor environments or areas with low traffic. It is used in areas intended for pedestrians and cyclists.

MINŐSÉGI FELTÉTELEK:

- According to SR EN 1433:2002
- According to EU Regulation No. 305/2011

ELŐNYÖK:

- resistance to high and low temperatures
- durable and corrosion-resistant material
- high resistance in aggressive environments
- hygienic, easy-to-clean surfaces

ÉLETTARTAM:

- 20 years - subject to compliance with assembly, storage and operation instructions

SZERELÉS

The grates are mounted over drains, manholes or access areas but only in areas with pedestrian traffic. We recommend that the installation be done by authorized personnel.

- !** For efficient installation, we recommend using G12M29-C sealant. It is used for sealing gutters, pipes and drainage systems.
- Curing time: 24h/2-3 mm
 - Operating temperature: +5° C to +40° C
 - Maximum storage temperature: 32° C



BASE sealant, construction products, 310 ml tube (G12M29-C).

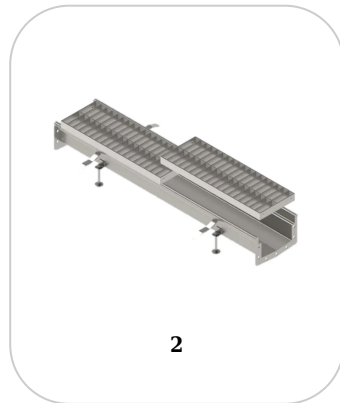
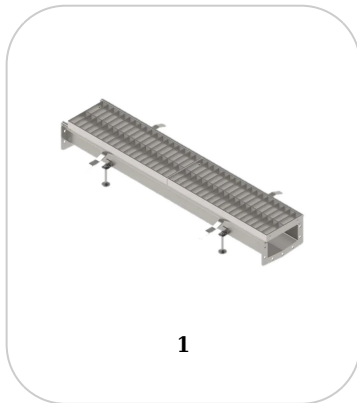

JELLEMZŐK

Termék neve Gratar INOX STAINLESS tip fante pentru rigola LN150 M125
498x176x30 (990341)

Termékkód 990341

EAN kód 6427669002673

Termékkategória Gratारे din inox

Brand Drain

Súly 4.57 kg

Készlet elérhetősége Tárolható

Hossz, mm

Szélesség, mm

Magasság (M), mm 30

Terhességi osztály M125

Termék anyaga Rozsdamentes acél

Garancia, hónap

Termelő