

Drain: Sifon FONTA URBAN M125 300X300 iesire verticala Dn110 (3335313-5)

3335313-5

300 mm
HOSSZ

125 mm
MAGASSÁG

300 mm
SZÉLESSÉG



FELHASZNÁLÁS:

The ductile iron trap for sewage is a useful, pragmatic, and modern solution used for collecting rainwater and directing it toward underground sewage lines.

MINŐSÉGI FELTÉTELEK:

Compliant with SR EN 1253-1:2015.

ELŐNYÖK:

- Attractive design
- Watertightness
- Thermal and mechanical resistance
- Use in residential areas or private homes
- Long lifespan
- Anti-slip

TERMÉKGARANCIA:

50 years - with proper adherence to installation, storage, and operation instructions.

SZERELÉS

It can be installed in private premises, yards, industrial halls, paved paths, or in areas with light traffic resistance, underground or subterranean garages/parking lots, etc.

! For efficient installation, we recommend using the G12M29C sealant. It is used for sealing trenches, pipes, and drainage systems.



- Cure time: 24 hours for 2-3 mm thickness
- Operating temperature: -10° C to +40° C
- Storage conditions: Store in a ventilated space at low temperatures

BASE sealant, construction products, 310 ml tube (G12M29-C).

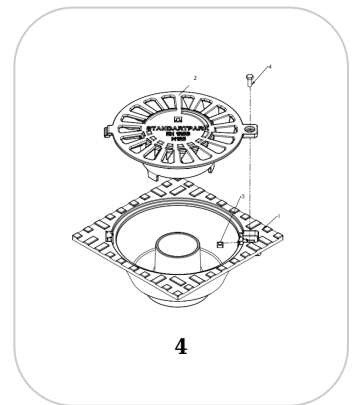
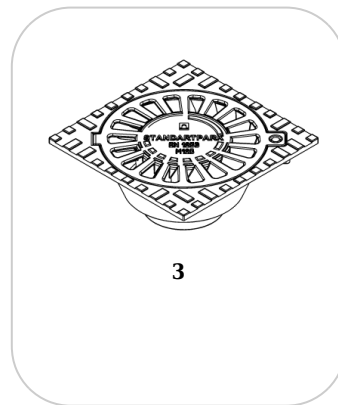
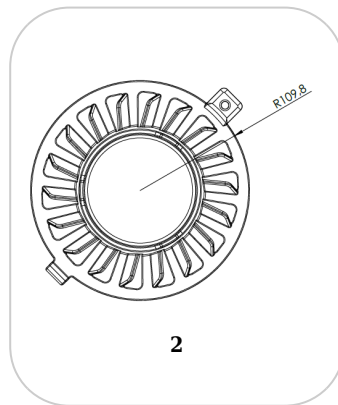
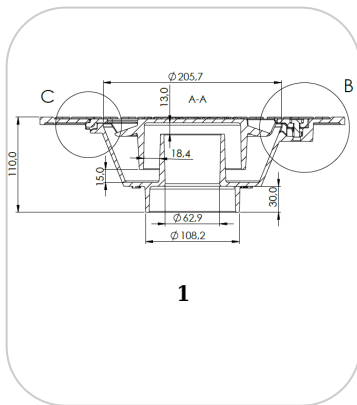

JELLEMZŐK

Termék neve	Sifon FONTA URBAN M125 300X300 iesire verticala Dn110 (3335313-5)
Termékkód	3335313-5
EAN kód	6426282034542
Termékkategória	Sifoane Fonta
Brand	Drain
Súly	9.20 kg
Készlet elérhetősége	Tárolható
Hossz, mm	300
Szélesség, mm	300
Magasság (M), mm	125
Belső átmérő / hézag (mm)	110
Külső átmérő (mm)	255
Terhességi osztály	M125
Termék anyaga	Öntöttvas
Rögzítőrendszer	surub
Termelő	