

Ø110

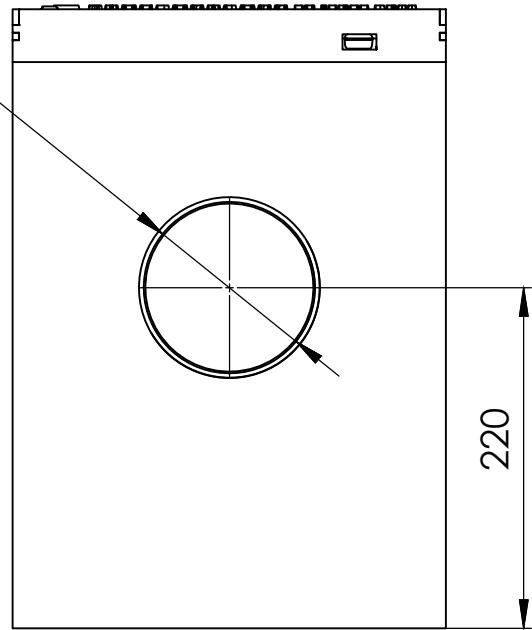

A

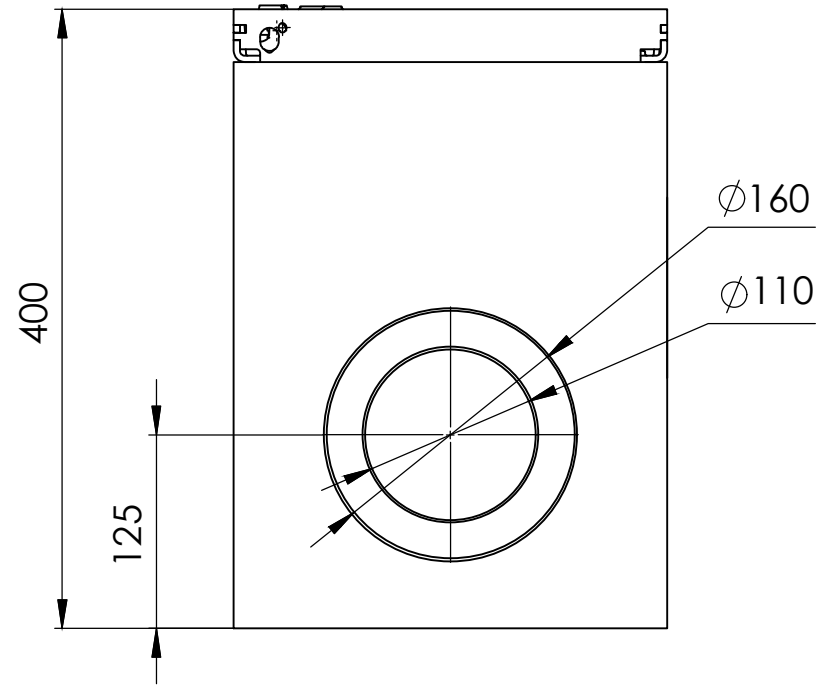

A-A

220

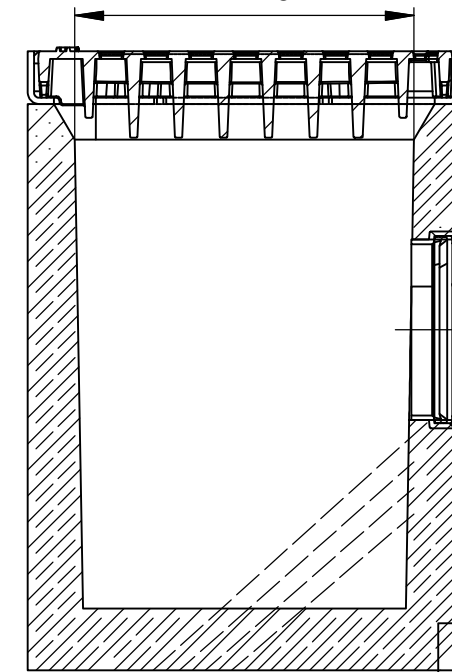

280

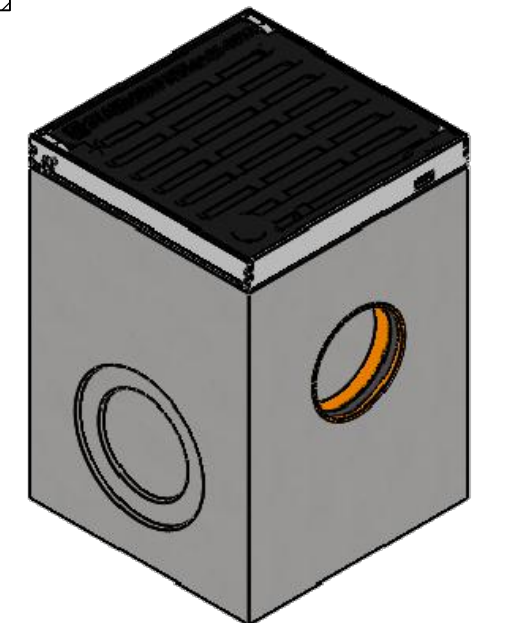
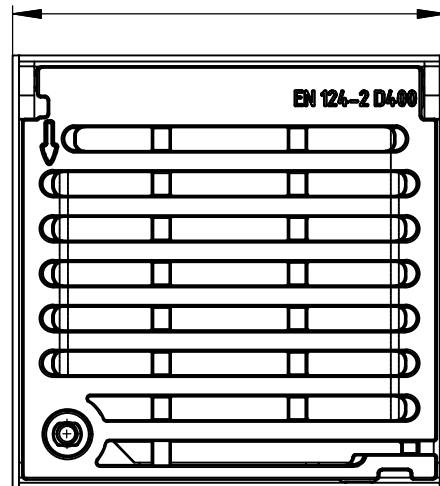

1. Dimensions for reference, mm
2. Delivery and packaging are carried out in accordance with the terms of the contract
3. The manufacturer reserves the right, without notice to the consumer, to make changes to the design of the products for improvement of their technological and operational parameters, which will not affect the quality and properties of the product.
Deviation of the actual weight of the nominal can be up to 10%

UNLESS OTHERWISE SPECIFIED: DIMENSIONS ARE IN MILLIMETERS SURFACE FINISH: TOLERANCES: ISO 2768-C LINEAR: ANGULAR:		FINISH:	DEBURR AND BREAK SHARP EDGES	DO NOT SCALE DRAWING	REVISION
NAME	SIGNATURE	DATE		 TITLE: 9" [DN220] Concrete Catch Basin PRO Set H16" [H400] Load class D400 ARTICLE: 045772084	
DRAWN					
CHK'D					
APPV'D					
MFG					
Q.A			MATERIAL: Ductile cast iron, Concrete, Steel, Plastic WEIGHT: 91.87 lb / 41.67 kg	SCALE: 1:5 SHEET 1 OF 1	

A3