

Channel: H100-H200

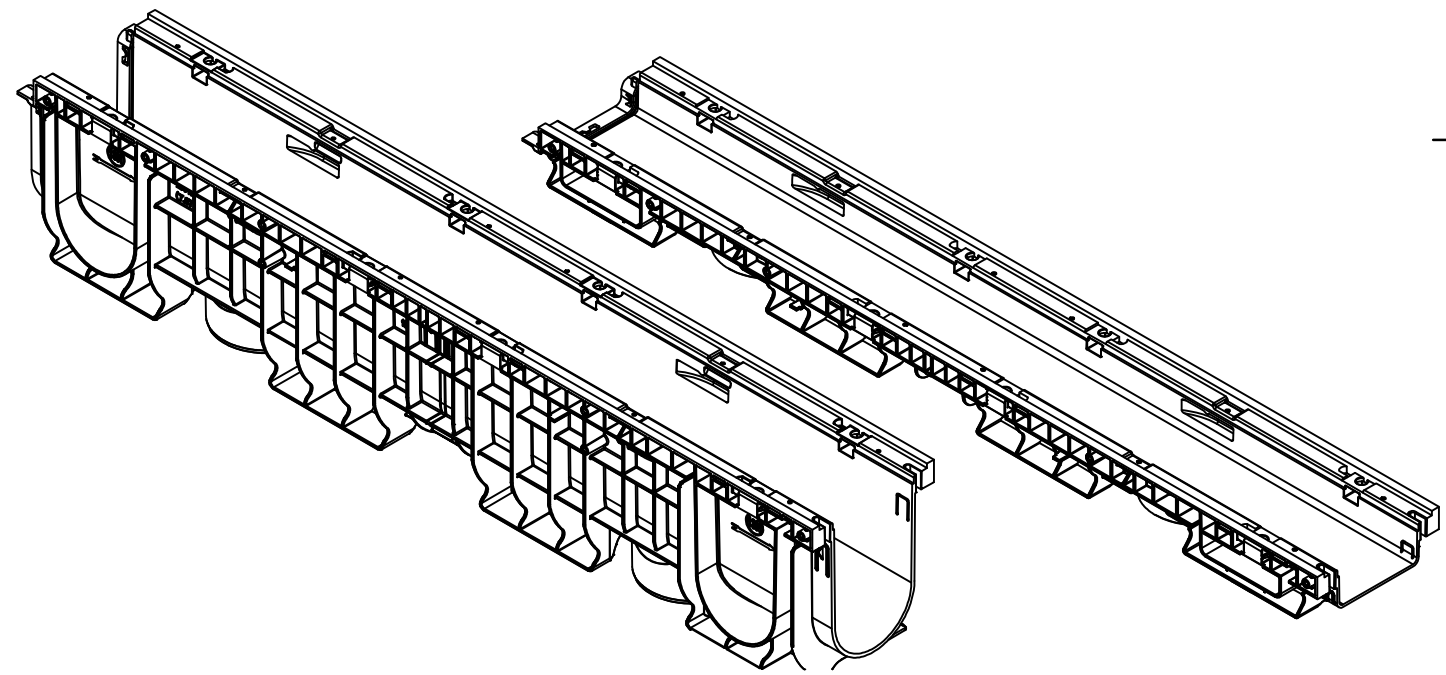
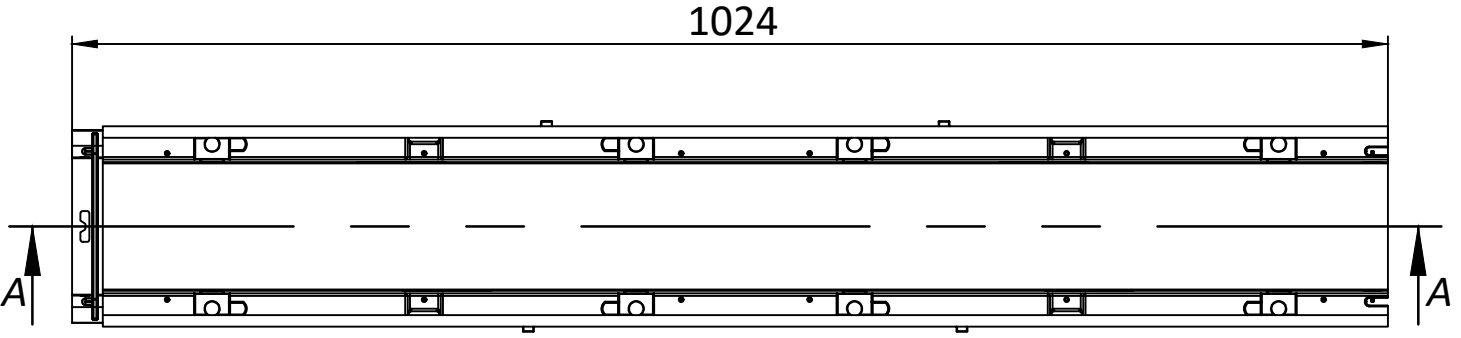
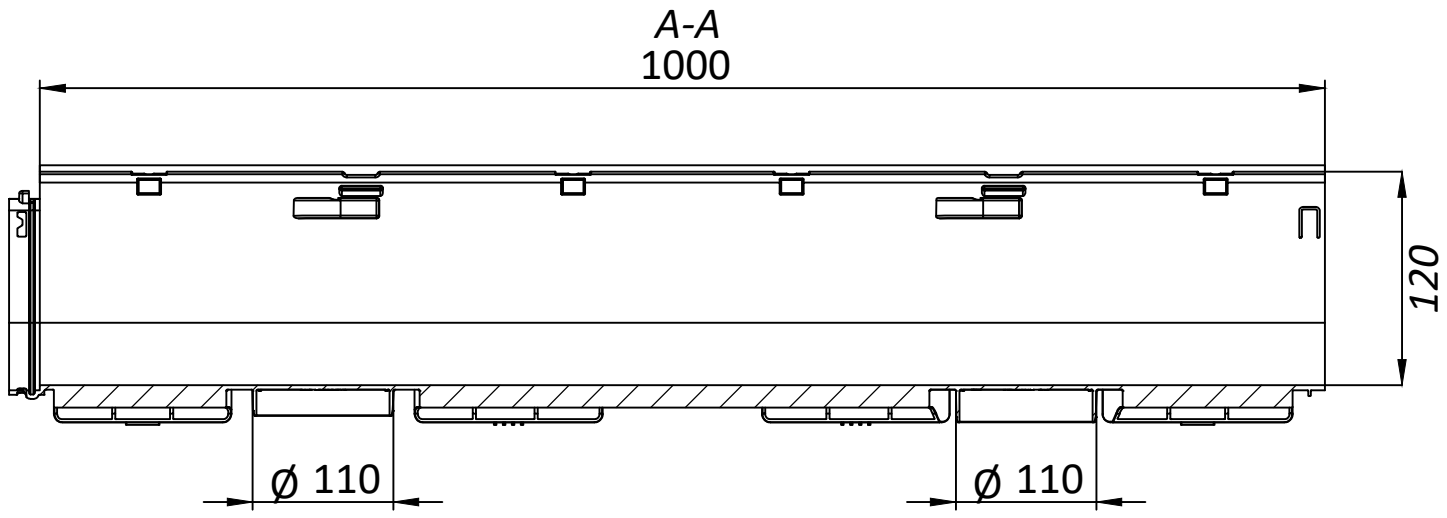
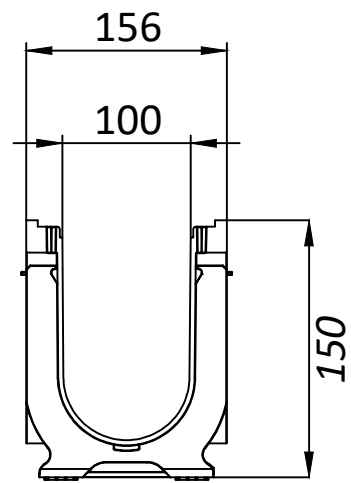

1. Deviation of the actual weight of the nominal can be up to 8%

UNLESS OTHERWISE SPECIFIED: DIMENSIONS ARE IN MILLIMETERS SURFACE FINISH: TOLERANCES: ISO 2768-c LINEAR: ANGULAR:				FINISH:		DO NOT SCALE DRAWING		REVISION	
						TITLE:			
						Plastic channel Base LN100 Hext.150			
						Load class: C250			
						ARTICLE:		A3	
						8000 (80150)			
						WEIGHT: 1.95		SCALE: 1:5	
								SHEET 1 OF 1	

	NAME	SIGNATURE	DATE
DRAWN	PSM		08.12.23
CHK'D	PMK		
APPV'D			
MFG			
Q.A			

