

Installation of Pro series plastic channels with a hydraulic cross-section LN100-300 into an asphalt concrete pavement

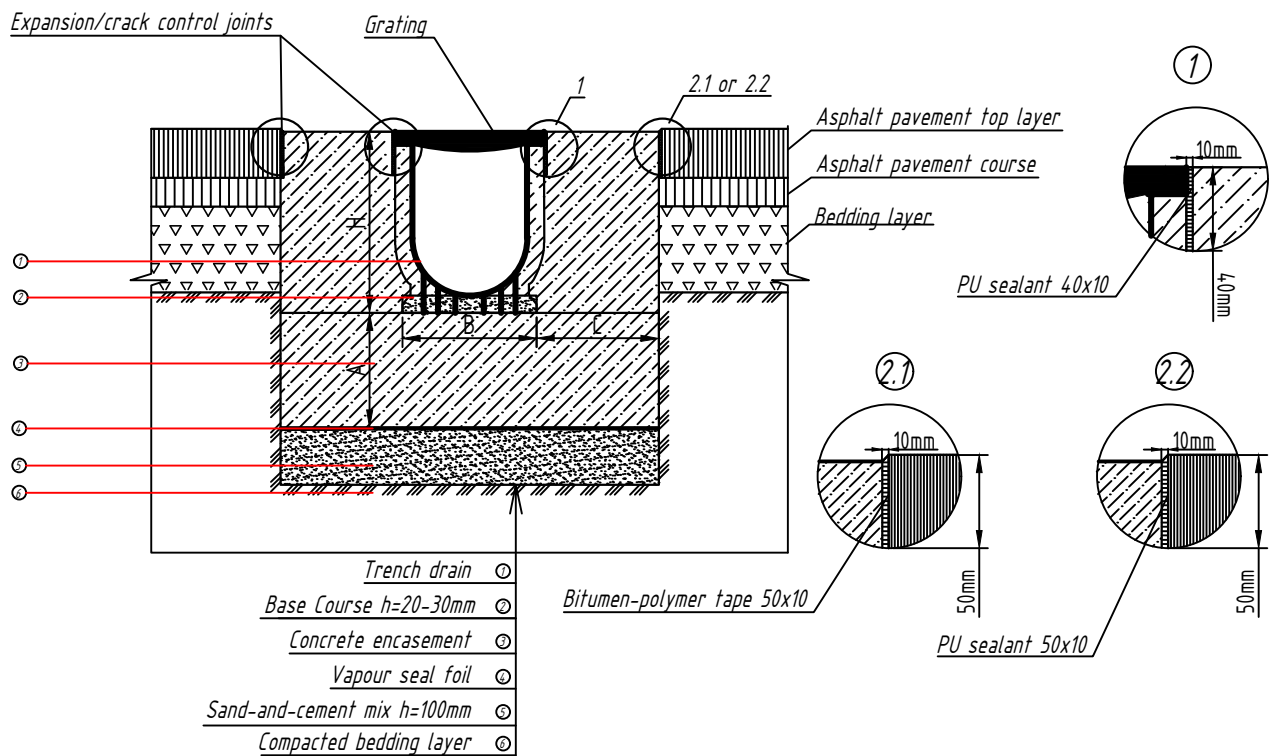

Recommended parameters of the Concrete encasement

Parameter	Load class		
	C250	D400	E600
Concrete encasement depth (A), mm	150	200	250
Concrete encasement width (C), mm	150	200	200
Compressive strength concrete class	C20/25	C20/25	C25/30

Notes

1. Parameters of bedding layer, concrete encasements as well as necessity of reinforcement must be selected according to geological conditions of the site.
2. If the line length of the trench drains line is more than 10m, expansion joints of the concrete encasement should be designed.
3. For compensation of temperature influence and deformation fluctuations of the adjoining pavement, it is recommended to arrange, at a distance of 250-500mm from the edge of the trench drain, longitudinal temperature /expansion joints.
4. Installation diagram is non-regulatory. Check updates on the Vodaland website.

Pro DN100-300 Asphalt

PD16-201119

Typical installation scheme of the rain water collection system

*Plastic trench drain Pro series
with hydraulic cross section
DN100-300*

Designed 20.11.19
Checked

16

Asphalt pavement trench drain installation

