

Channel: H100-H200

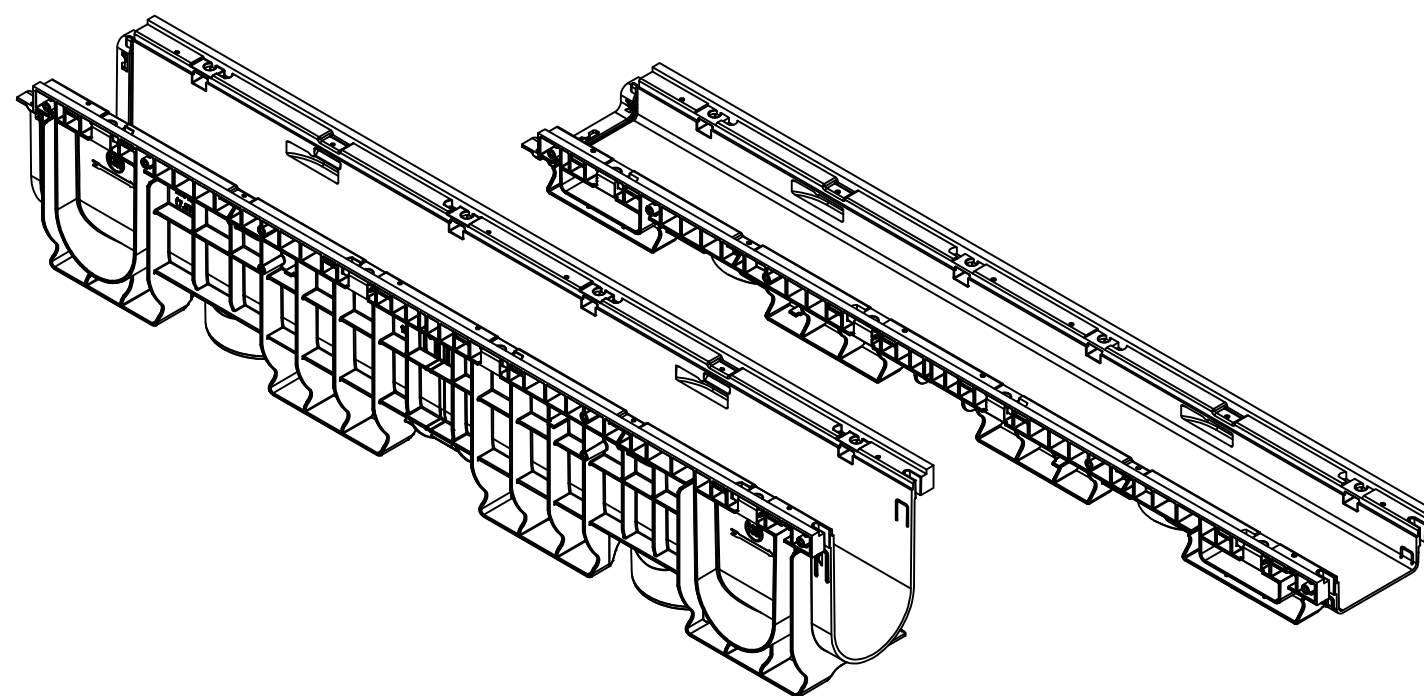
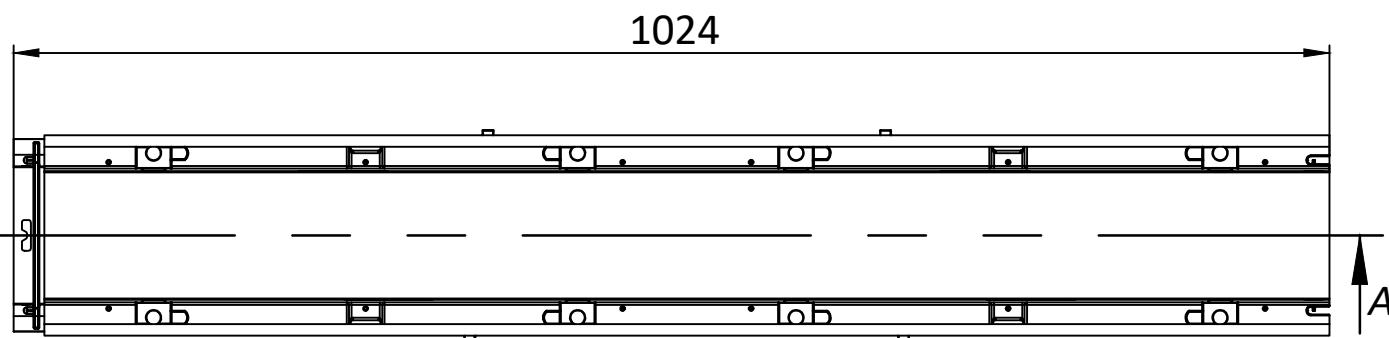
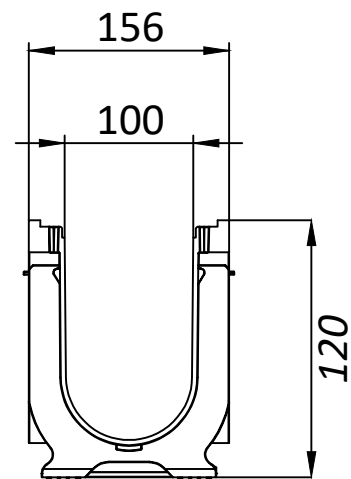

1. Deviation of the actual weight of the nominal can be up to 8%

UNLESS OTHERWISE SPECIFIED: FINISH: DIMENSIONS ARE IN MILLIMETERS SURFACE FINISH: TOLERANCES: ISO 2768-c LINEAR: ANGULAR:				DO NOT SCALE DRAWING		REVISION	
				TITLE: Plastic channel Base LN100 Hext.120			
				Load class: C250			
DRAWN: PSM		SIGNATURE:		DATE: 08.12.23		ARTICLE: 8020 (80120)	
CHK'D: PMK						A3	
APPV'D:							
MFG:							
Q.A:				MATERIAL:			
				WEIGHT: 1.64		SCALE: 1:5	
						SHEET 1 OF 1	

6

5

4

3

2

1

D

D

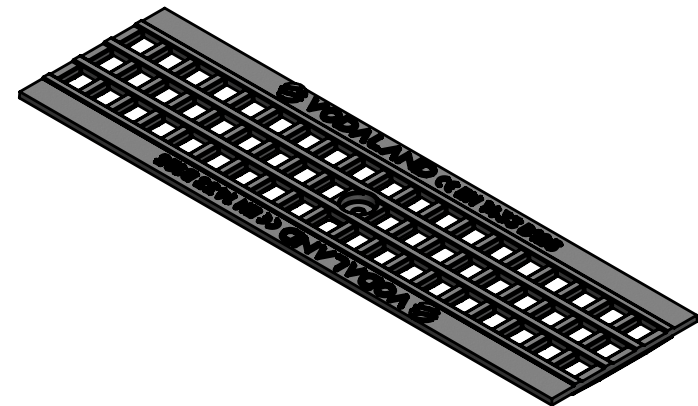
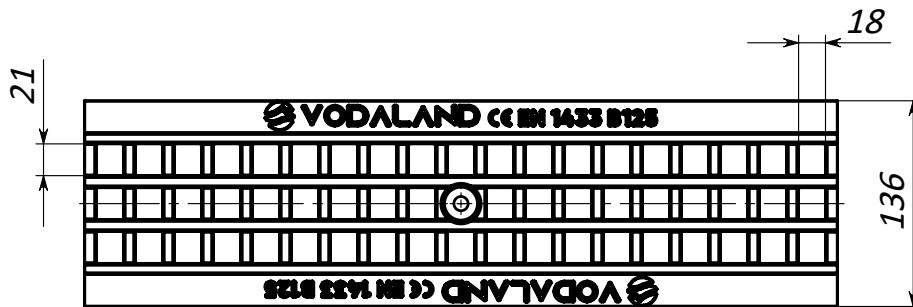
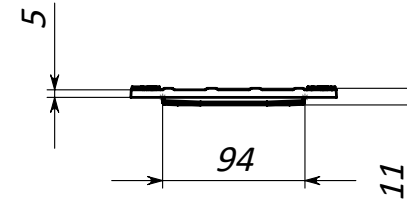
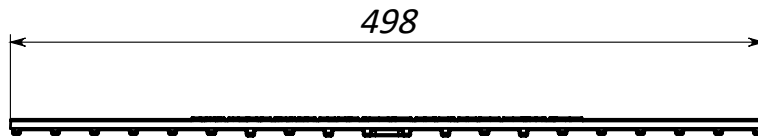

1. Area of water intake slots 208.88 sq cm ;
2. Deviation of the actual weight of the nominal can be up to 10%

UNLESS OTHERWISE SPECIFIED:
DIMENSIONS ARE IN MILLIMETERS
SURFACE FINISH:
TOLERANCES: 2768-c
LINEAR:
ANGULAR:

FINISH:

DO NOT SCALE DRAWING

REVISION



	NAME	SIGNATURE	DATE		
DRAWN	LMV		13.05.22		
CHK'D	LMK				
APPV'D					
MFG					
Q.A				MATERIAL:	Cast iron
				WEIGHT:	2.08 kg

TITLE:

Cast iron grate Base DN100 mesh B125

Load class: B125

Article:

20402

A4

SCALE:1:5

SHEET 1 OF 1

B

B

A

A

6

5

4

3

2

1