

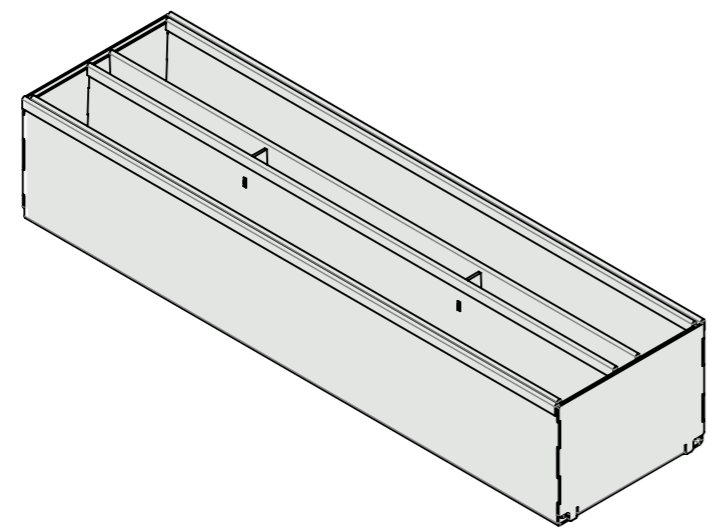

1. Deviation of the actual weight of the nominal can be up to 8%

UNLESS OTHERWISE SPECIFIED: DIMENSIONS ARE IN MILLIMETERS SURFACE FINISH: TOLERANCES: ISO 2768-c LINEAR: ANGULAR:				FINISH:		DO NOT SCALE DRAWING		REVISION	
						TITLE: Plastic sand trap Base DN100 H350 with basket and adapters (2 pcs.)			
DRAWN: PSM		SIGNATURE:		DATE: 16.05.24		ARTICLE: 808018.9		A3	
CHK'D: PMK						MATERIAL: Polipropilena			
APPV'D:						WEIGHT: 2.80		SCALE: 1:5	
MFG:								SHEET 1 OF 1	
Q.A:									

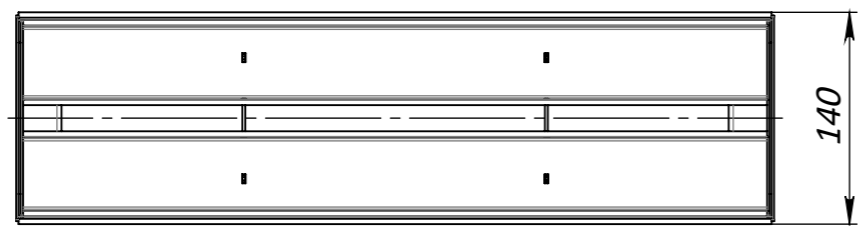
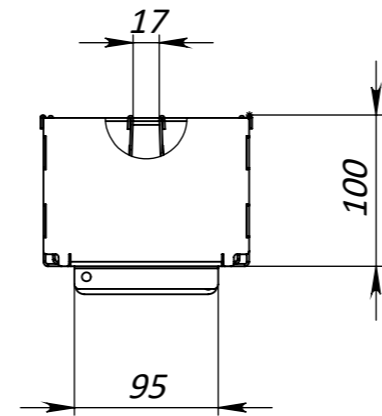
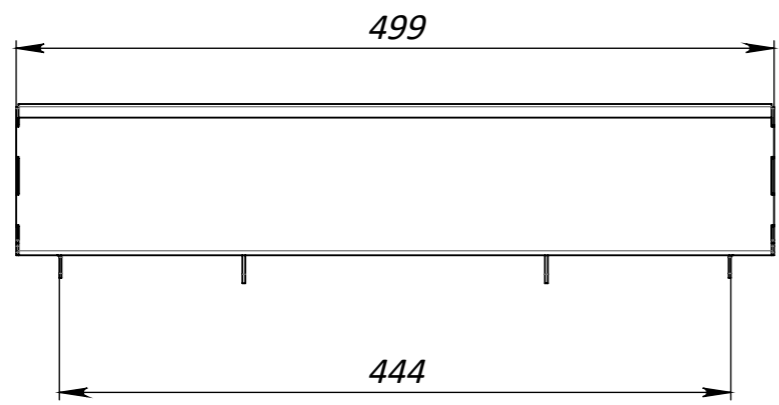

1. Dimensions for reference.
2. Hot dip galvanized according to ISO 1461:2009.
3. Delivery and packaging are carried out in accordance with the terms of the contract
4. The manufacturer reserves the right, without notice to the consumer, to make changes to the design of the products for improvement of their technological and operational parameters, which will not affect the quality and properties of the product.
5. Load class can be achieved according to intallation scheme.

UNLESS OTHERWISE SPECIFIED: DIMENSIONS ARE IN MILLIMETERS SURFACE FINISH: TOLERANCES: ISO 2768-m LINEAR: ANGULAR:		FINISH: <b>Hot dip galvanized</b>		DEBURR AND BREAK SHARP EDGES		DO NOT SCALE DRAWING		REVISION V.2					
						 <b>Galvanized Steel Slot Drain</b> <b>Revision T-type H100 Base</b> <b>DN100 Channel A15-C250</b> Load class A15-C250							
DRAWN		NAME		SIGNATURE						DATE		TITLE:	
CHK'D		Markovych								17.08.22			
APPV'D													
MFG													
Q.A								MATERIAL:					
								Galvanized Steel					
								ARTICLE:					
								20175-1T-100					
								A3					
								WEIGHT: 5.21 kg					
								SCALE:1:5					
								SHEET 1 OF 1					