

B (3 : 5)

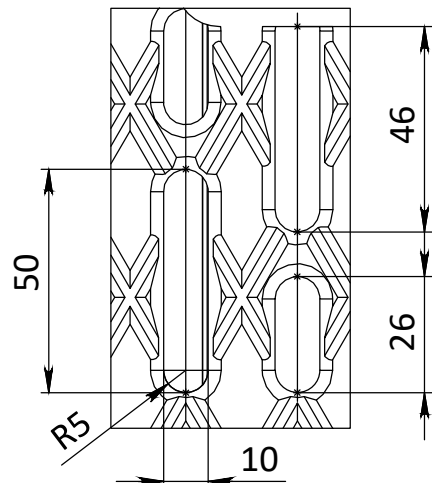

1. Deviation of the actual weight of the nominal can be up to 8%
2. Area of water intake slots 139.7 sq cm

UNLESS OTHERWISE SPECIFIED: DIMENSIONS ARE IN MILLIMETERS SURFACE FINISH: TOLERANCES: ISO 2768-c LINEAR: ANGULAR:				FINISH:		DO NOT SCALE DRAWING		REVISION	
DRAWN LIL				SIGNATURE		DATE 14.10.22		TITLE: Plastic sand trap Easy DN100 H250 with plastic slotted grate A15 without basket	
CHK'D LMK								Load class: A15	
APPV'D								ARTICLE: 0888081 (0888081.7)	
MFG								A3	
Q.A						MATERIAL:		WEIGHT: 1,42 kg	
								SCALE:1:5	
								SHEET 1 OF 1	