

Primary Usage	
Reference No.	
Sign. and date	
Copy inv. No.	
Repl. Inv. No.	
Sign. and date	
Orig. Inv. No.	

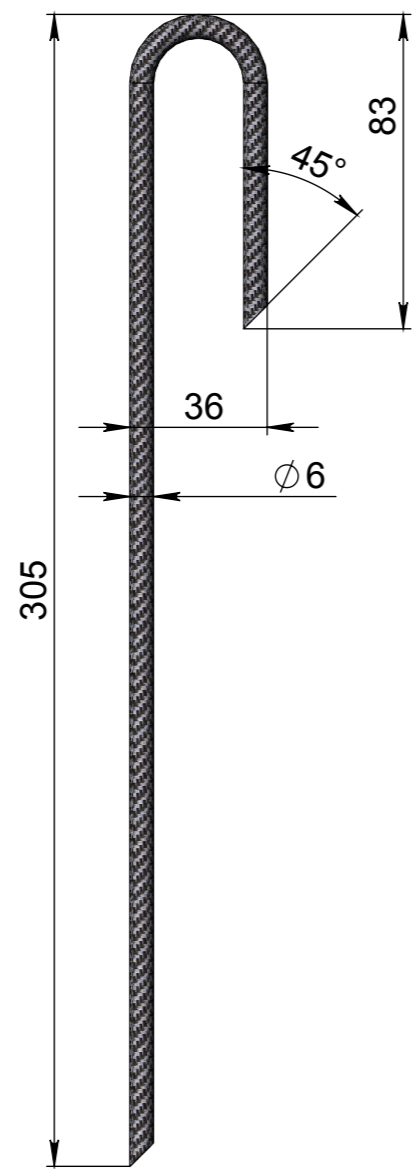

- * - Dimensions for reference;
- Delivery and packaging are carried out in accordance with the terms of the contract
- The manufacturer reserves the right, without notice to the consumer, to make changes to the design of the products for improvement their technological and operational parameters, which will not affect the quality and properties of the product.

					Art. 1930
					AGR-30-OS - 1930
					Let. Weight Scale
Rev.	Sheet	Doc. No.	Sign.	Data	Anchor J shaped
				13.05.20	
					Sheet Sheets 1
Galvanized Steel					VODALAND