

Grease Separator with a sludge double trap GPro-4 (S1:25)

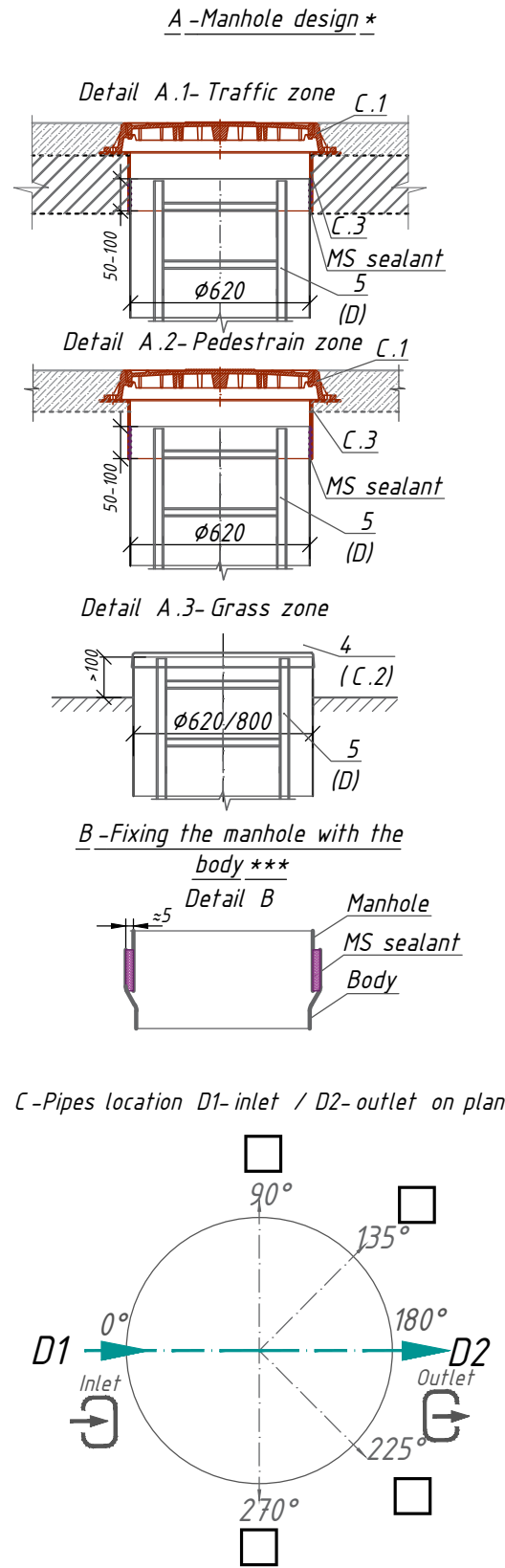
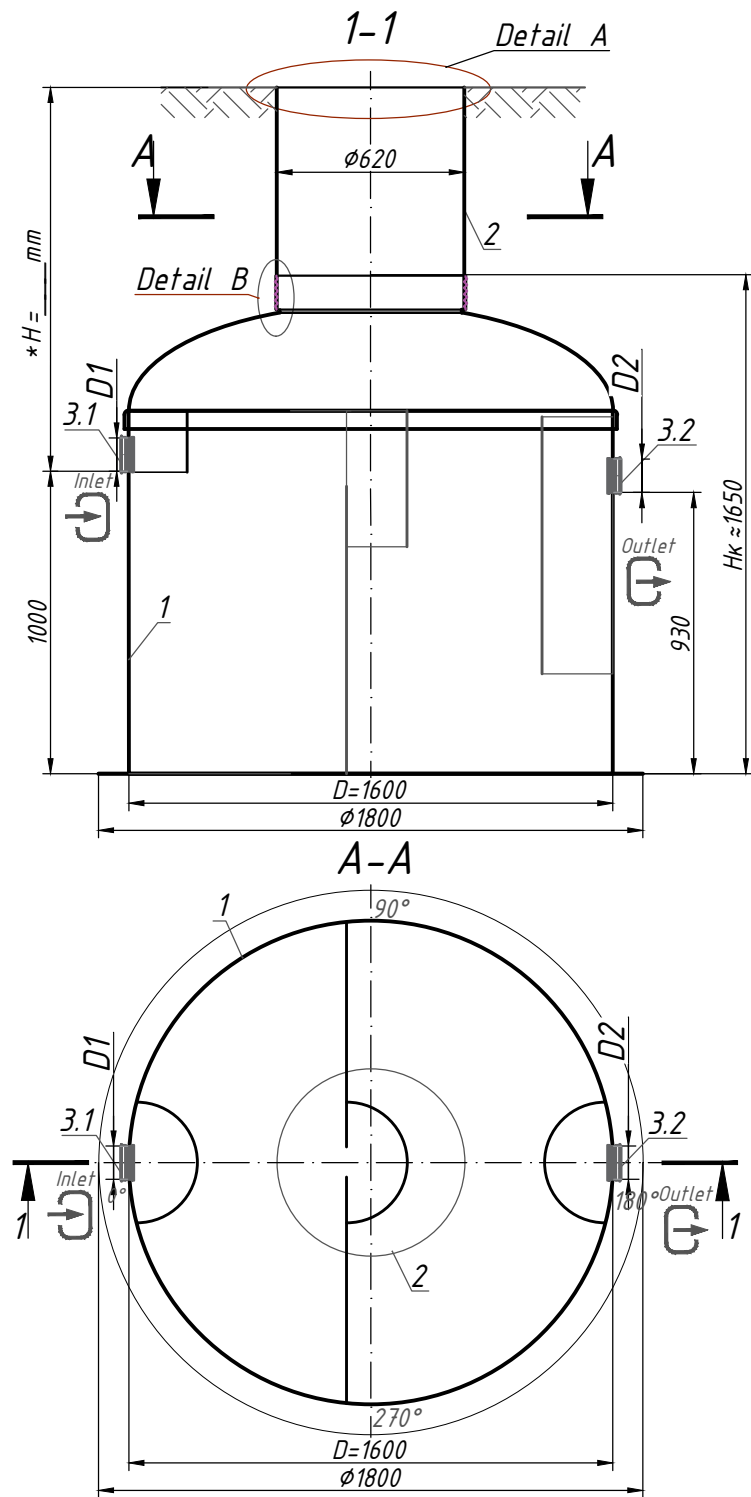

Specification of materials and equipment Standard equipment \*\* (Tabl. 1)

Pos.	Identification	Name	Q-ty	Mass.pc .kg	Note
1	Vodaland	Grease Separator Vodaland GreasePro-4 with a sludge double trap, disch 4 l/s, fiberglass D=1600 Hk=1650 mm	1	306	compl.
2		Inspection manhole Ø 620	1		compl.
3.1	D1-Inlet pipe	Rubber seal for connection PVC SN4 Ø 110	1		compl.
3.2	D2-Outlet pipe	Rubber seal for connection PVC SN4 Ø 110	1		compl.
		Volume of light liquids	295		l
		Volume of sludge trap	630		l

\*\* The product is shipped in accordance with the Standard equipment (Tabl. 1), unless otherwise specified in the Additional equipment (Tabl. 2)

Additional equipment (Tabl. 2)

Pos.	Identification	Name			Note
A, B	D1-Inlet pipe / D2-Outlet pipe:		<input type="checkbox"/>	<input type="checkbox"/>	
	For connection D1, D2:				
	Funnel		<input type="checkbox"/>	<input type="checkbox"/>	
	Smooth end		<input type="checkbox"/>	<input type="checkbox"/>	
C	Diametr D pipes D1, D2:		<input type="checkbox"/>	<input type="checkbox"/>	
	Ø 90		<input type="checkbox"/>	<input type="checkbox"/>	
	Ø 160		<input type="checkbox"/>	<input type="checkbox"/>	
	Another:		<input type="checkbox"/>	<input type="checkbox"/>	
C	Manhole design (see A.1, A.2)				
	C.1 Cover:	Garden plastic	<input type="checkbox"/>		
		Load class A 15	<input type="checkbox"/>		
		Load class C 250	<input checked="" type="checkbox"/>		
	C.2	Load class D 400	<input type="checkbox"/>		
Fiberglass cover Ø 620		<input type="checkbox"/>			
C.3 Fiberglass adaptor plate Ø 620, h=200mm		<input checked="" type="checkbox"/>			
D	D. Universal ladder		<input type="checkbox"/>		
	Aluminium		<input type="checkbox"/>		
E	E. Level sensor		<input type="checkbox"/>		
	Oil		<input type="checkbox"/>		
F	F. Fastening		<input type="checkbox"/>		
	Belt fastening for D 1600		<input type="checkbox"/>		

Note:

\*H-depth of the inlet connection, mm (in standard equipment H up to 2000 mm). H take a multiple of 50mm.  
 When filling the manhole A.1 - the overall height of the product is less than 200mm; at the design of the manhole A.2 - the total height of the product is bigger than 100 mm.  
 \*\*The product is shipped in accordance with the Standard equipment (Tabl. 1), unless otherwise specified in the Additional equipment (Tabl. 2). The complete set of the product agrees with the manager.  
 \*\*\*The manufacturer has the right to make constructive and pattern changes that do not worsen the characteristics of the product as a whole  
 Permissible deviation during production of products is 1-3%.

Additional equipment: \_\_\_\_\_

\_\_\_\_\_

Chan.	Q-ty	Sheet	Nºdoc.	Signature	Date	Phase	Sheet	Sheets
Grease Separator GPro-4 (GP-4)								