

Oil and sand Separator OilBase100 -1/0 (M1:20)

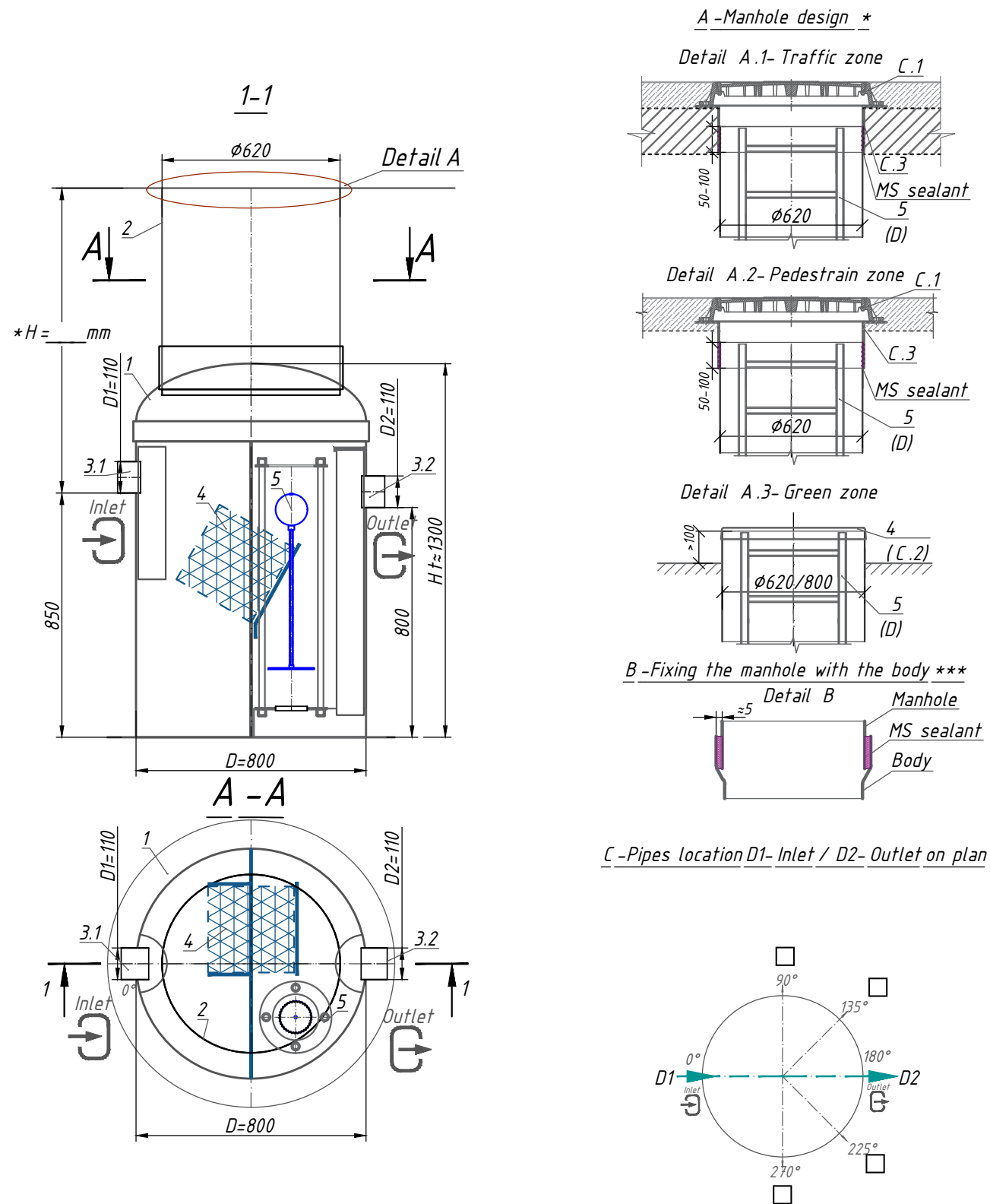

Specification of materials and equipment. Standard equipment ** (Tabl. 1)

Pos.	Identification	Name	Q-ty	Mass pc.,kg	Note
1	Vodaland	Oil and sand Separator Vodaland OilBase100 -1/0, disch. 1l/s, (0 l/s -ByPass) fiberglass, D= 800, Ht≈ 1300 mm	1	70	compl.
2		Inspection manhole Ø800 / 620	0/ 1		compl.
3,1,3,2	D1-Inlet / D2-Outlet	Rubber seal for connection PVC SN4 Ø 110	2		compl.
4		Coalescent block	1		compl.
5		Automatic locking device 110	1		compl.
		Volume of light liquids	50		l
		Volume of sludge trap	100		l

**The product is shipped according to Standard Equipment (Tabl. 1), unless otherwise specified in the Additional Equipment (Tabl. 2)

Additional equipment (Tabl. 2)

Pos.	Identification	Name			Note		
A, B	D1-Inlet / D2-Outlet:	A.For connection D1, D2:	PVC	<input type="checkbox"/>	<input type="checkbox"/>		
			PE 100	<input type="checkbox"/>	<input type="checkbox"/>		
			Corsis	<input type="checkbox"/>	<input type="checkbox"/>		
			B.Diameter D1, D2:	D1 _____ / D2 _____	<input type="checkbox"/>		<input type="checkbox"/>
			Another: _____	<input type="checkbox"/>	<input type="checkbox"/>		
C	Manhole design (see A.1, A.2, A.3)	C.1 Cover:	Garden plastic	<input type="checkbox"/>			
			Load class A15	<input type="checkbox"/>			
			Load class C250	<input type="checkbox"/>			
			Load class D400	<input type="checkbox"/>			
		C.2 Fiberglass cover:	Ø620	<input type="checkbox"/>			
C.3 Fiberglass adaptor plate:	Ø620, h=200 mm	<input type="checkbox"/>					
	Another: _____	<input type="checkbox"/>					
D	D. Universal ladder	Aluminium	<input type="checkbox"/>				
		s/s	<input type="checkbox"/>				
E	E. Fastening	Belt fastening for	<input type="checkbox"/>				
H	H. Level sensor	Sludge	<input type="checkbox"/>				
		Oil	<input type="checkbox"/>				
		Another: _____	<input type="checkbox"/>				

Note:
 *H-depth of the inlet connection, mm (in standard equipment H up to 2000 mm). H take a multiple of 50mm.
 When filling the manhole A.1-the overall height of the product is less than 200mm; A.2-the total height of the product is bigger than 100 mm.
 **The product is shipped according to Standard Equipment (Tabl. 1), unless otherwise specified in the Additional Equipment (Tabl. 2). The complete set of the product agrees with the manager.
 ***The product is shipped according to Standard Equipment (Tabl. 1), unless otherwise specified in the Additional (Tabl. 2) Permissible deviation during production of products is 1-3%.

Additional Information:

Rev.	Q-ty	Sh.	Nºdoc.	Sign.	Date	Stage	Sheet	Sheets

Oil and sand Separator OilBase100 -1/0 (OB1- 1)

