

Oil Separator with sludge trap OilBaseH100 -25 (S 1:30)

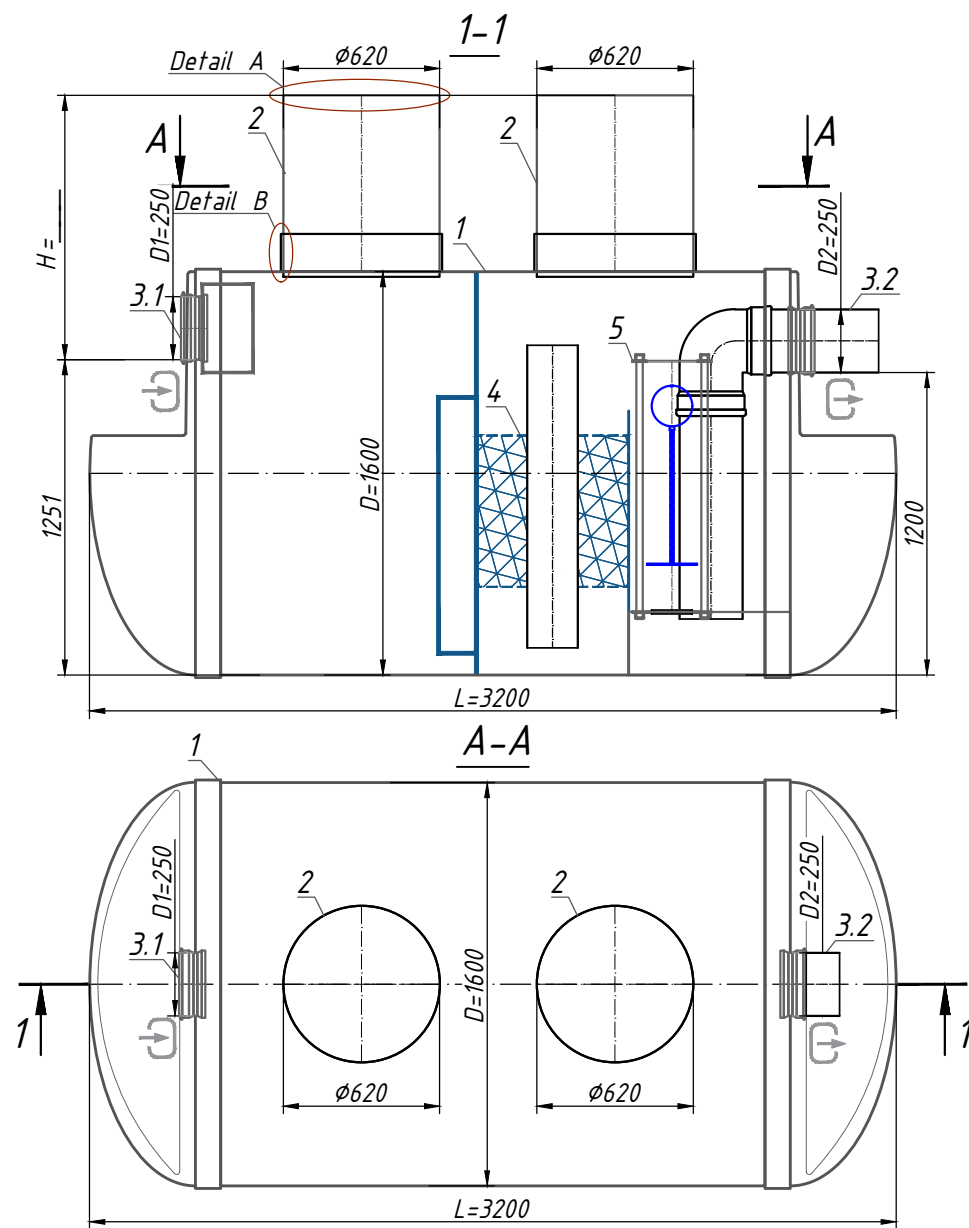

A -Manhole design *

B -Fixing the manhole with the body ***

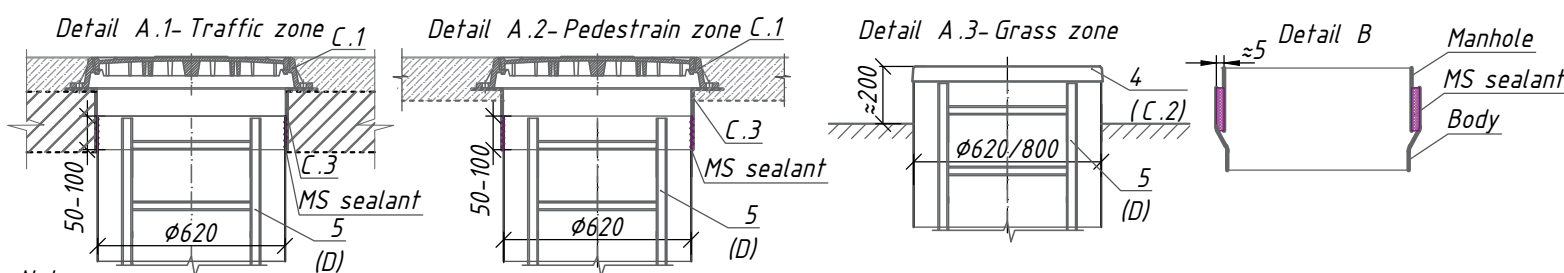

Note:

*H-depth of the inlet connection, mm (in standard equipment H up to 2000 mm). H take a multiple of 50mm.
When filling the manhole A.1-the overall height of the product is less than 200mm; A.2-the total height of the product is bigger than 100 mm.

**The product is shipped according to Standard Equipment (Tabl. 1), unless otherwise specified in the Additional Equipment (Tabl. 2).
The complete set of the product agrees with the manager.

***The product is shipped according to Standard Equipment (Tabl. 1), unless otherwise specified in the Additional (Tabl. 2)
Permissible deviation during production of products is 1-3%.

Additional Information:

Specification of materials and equipment. Standard equipment ** (Tabl. 1)

Pos.	Identification	Name	Q-tu	Mass ps.,kg	Note
1	Vodaland	Oil Separator with sludge trap Vodaland OilBaseH100 -25, disch 25l/s, fiberglass, D= 1600, L= 3200 mm	1		compl.
2		Inspection manhole $\phi 800 / 620$	0/2		compl.
3.1,3.2		For connection PVC SN4 $\phi 250$	2		compl.
4		Coalescent block	1		compl.
5		Automatic closure device	1		compl.
		Volume of light liquids	1250		l
		Volume of sludge trap	2500		l

**The product is shipped according to Standard Equipment (Tabl. 1), unless otherwise specified in the Additional Equipment (Tabl. 2)

Additional equipment (Tabl. 2)

Pos.	Identification	Name	Note
A, B	D1-Inlet / D2-Outlet: ⊗ ⊕		
	A.For connection D1, D2:	PVC	<input type="checkbox"/>
		PE100	<input type="checkbox"/>
		Corsis	<input type="checkbox"/>
	B.Diameter D1, D2:	D1 _____ / D2 _____	<input type="checkbox"/>
		Another: _____	<input type="checkbox"/>
C	Manhole design (see A.1, A.2, A.3)		
	C.1 Cover:	Garden plastic	<input type="checkbox"/>
		Type "L" class A15	<input type="checkbox"/>
		Type "T" class C250	<input type="checkbox"/>
		Type "TM" class D400	<input type="checkbox"/>
	C.2 Fiberglass cove:	$\phi 620$	<input type="checkbox"/>
C.3 Fiberglass adaptor plate: $\phi 620, h=200$ mm		<input type="checkbox"/>	
	Another: _____	<input type="checkbox"/>	
D	D. Universal ladder	Aluminium	<input type="checkbox"/>
		s/s	<input type="checkbox"/>
E	E. Fastening	Belt fastening for	<input type="checkbox"/>
H	H. Level sensor	Sludge	<input type="checkbox"/>
		Oil	<input type="checkbox"/>
		Another: _____	<input type="checkbox"/>

Rev.	Q-tu	Sh.	Nºdoc.	Sign	Date

Stage	Sheet	Sheets

Oil Separator with sludge trap
OilBaseH100 -25
(OBH1- 25)

