

Oil Separator with sludge trap OilBaseH100 -275 (S 1:40)

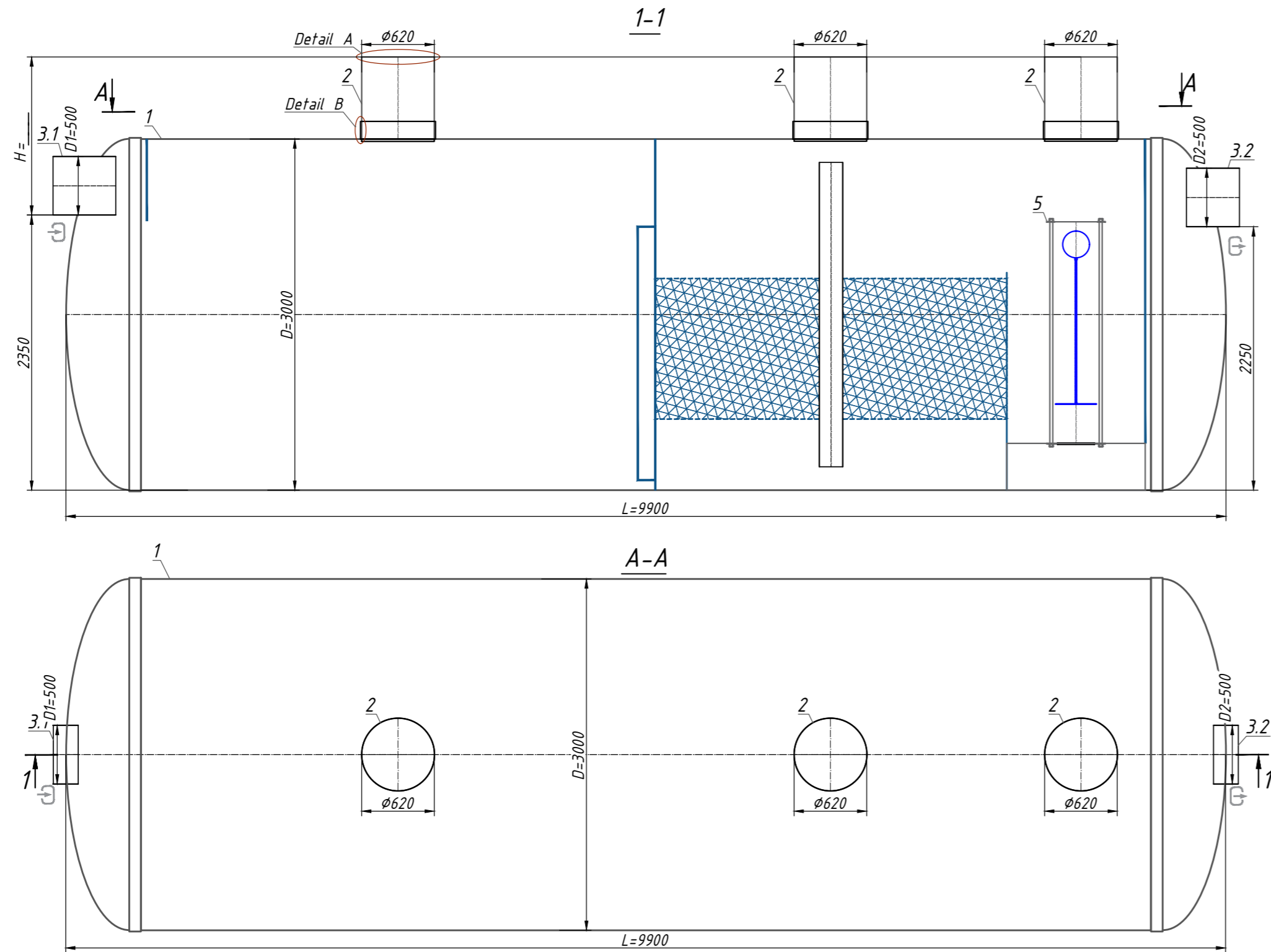

Note:

- *H-depth of the inlet connection, mm (in standard equipment H up to 2000 mm). H take a multiple of 50mm. When filling the manhole A.1-the overall height of the product is less than 200mm; A.2-the total height of the product is bigger than 100 mm.
- **The product is shipped according to Standard Equipment (Tabl. 1), unless otherwise specified in the Additional Equipment (Tabl. 2). The complete set of the product agrees with the manager.
- ***The product is shipped according to Standard Equipment (Tabl. 1), unless otherwise specified in the Additional (Tabl. 2) Permissible deviation during production of products is 1-3%.

Additional Information:

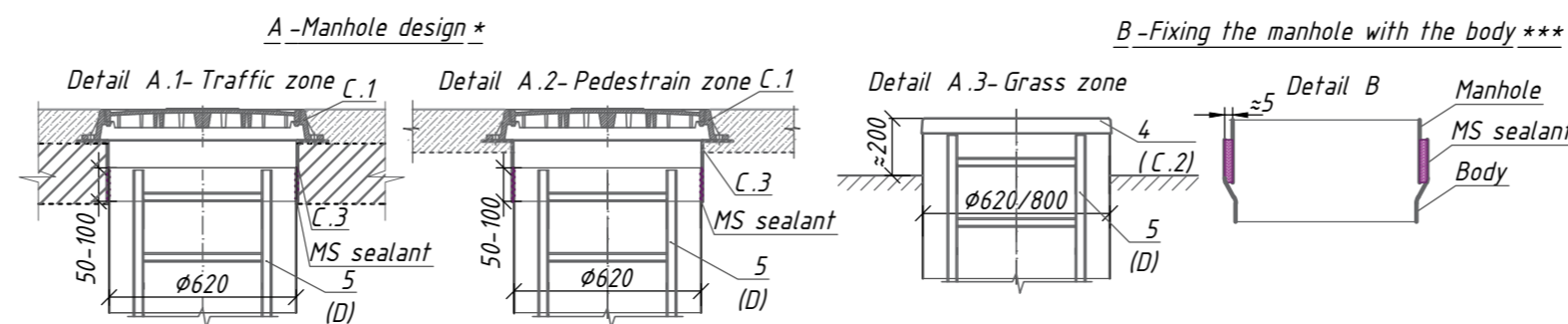

Specification of materials and equipment. Standard equipment ** (Tabl. 1)

Pos.	Identification	Name	Q-tu	Mass ps.,kg	Note
1	Vodaland	Oil Separator with sludge trap Vodaland OilBaseH100 -275, disch 275 l/s, fiberglass, D= 3000, L= 9900	1		compl.
2		Inspection manhole $\phi 800 / 620$	0/3		compl.
3,1,3,2	D1-Inlet / D2-Outlet	For connection PVC SN4 $\phi 500$	2		compl.
4		Coalescent block	1		compl.
5		Automatic closure device	1		compl.
		Volume of light liquids		13750	l
		Volume of sludge trap		27500	l

** The product is shipped according to Standard Equipment (Tabl. 1), unless otherwise specified in the Additional Equipment (Tabl. 2)

Additional equipment (Tabl. 2)

Pos.	Identification	Name	Note
A, B	A.For connection D1, D2:	D1-Inlet / D2-Outlet: \ominus \oplus	
		PVC	<input type="checkbox"/> <input type="checkbox"/>
		PE100	<input type="checkbox"/> <input type="checkbox"/>
		Corsis	<input type="checkbox"/> <input type="checkbox"/>
		B.Diameter D1, D2:	D1 _____ / D2 _____
	Another: _____	<input type="checkbox"/> <input type="checkbox"/>	
C	Manhole design (see A.1, A.2, A.3)		
	C.1 Cover:	Garden plastic	<input type="checkbox"/>
		Type "L" class A15	<input type="checkbox"/>
		Type "T" class C250	<input type="checkbox"/>
		Type "TM" class D400	<input type="checkbox"/>
C.2 Fiberglass cove:	$\phi 620$	<input type="checkbox"/>	
C.3 Fiberglass adaptor plate:	$\phi 620$, h=200 mm	<input type="checkbox"/>	
	Another: _____	<input type="checkbox"/>	
D	D. Universal ladder	Aluminium	<input type="checkbox"/>
		s/s	<input type="checkbox"/>
E	E. Fastening	Belt fastening for	<input type="checkbox"/>
H	H. Level sensor	Sludge	<input type="checkbox"/>
		Oil	<input type="checkbox"/>
		Another: _____	<input type="checkbox"/>

Rev.	Q-tu	Sh.	Nºdoc.	Sign	Date	Stage	Sheet	Sheets
Oil Separator with sludge trap OilBaseH100 -275 (OBH1- 275)								